



High Flow Miniature Proportional Valve

Kelly Pneumatics, offers a High Flow Miniature Proportional Valve utilizing our unique proportional valve design.

This non-spool valve architecture employs one moving part, ensuring virtually friction-less proportional control and longevity tested over 100 million cycles.

The simplicity of the proportional valve design also ensures relative ease when implementing maintenance or cleaning. We also offer alternative versions that are resistant to both high and low temperatures, therefore performing consistently in many different environments.



Specifications

Valve Function	2 Way, Normally Closed
Electrical Connection	Flying Wire Leads
Working Pressure	-14.7 to 100 psig (6.8 bar) (standard) 500 (psig) (custom)
Flow Range	0 - 90 liters per minute of air flow
Orifice Size	.040, .060, .090, .125, or .156 inches
Port Types	1/8" NPT (base Mount) or Manifold Mount
Seal Material	Buna-N, Viton, or EPDM
Operating Temp.	-40° to 200 ° F (-40 ° to 93 ° C)
Maximum Hysteresis	2-10% of full current (varies with max flow)
Leak Rate	Bubble Tight Seal
Weight	0.25 lbs
Filtration	40 Micron Recommended
Power	4.2 watts(max)
Wetted Materials	Cold rolled stainless steel w/ electroless nickel plating, brass and 304 stainless steel

Dimensions

(All Dimensions in Inches)

Base Mount Version

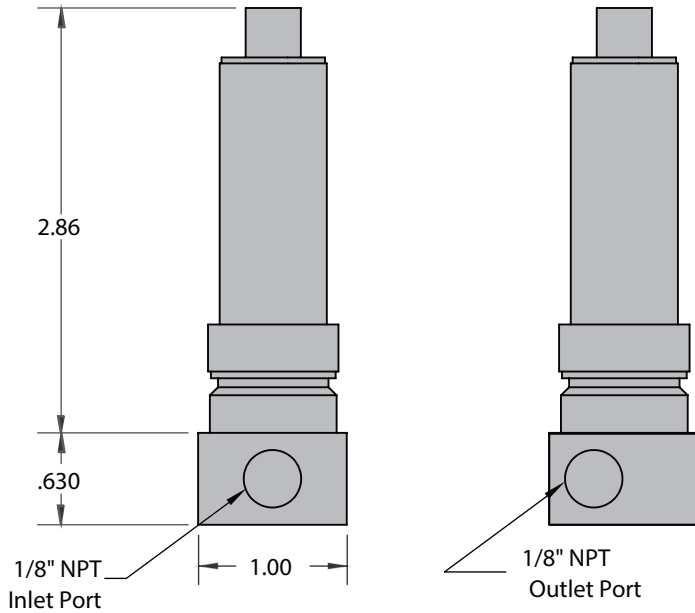

Manifold Mount Version

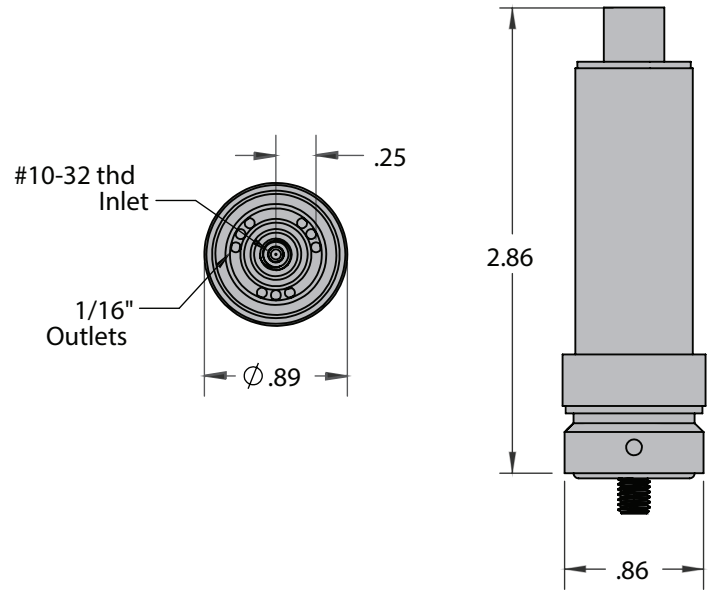

Part Numbering System

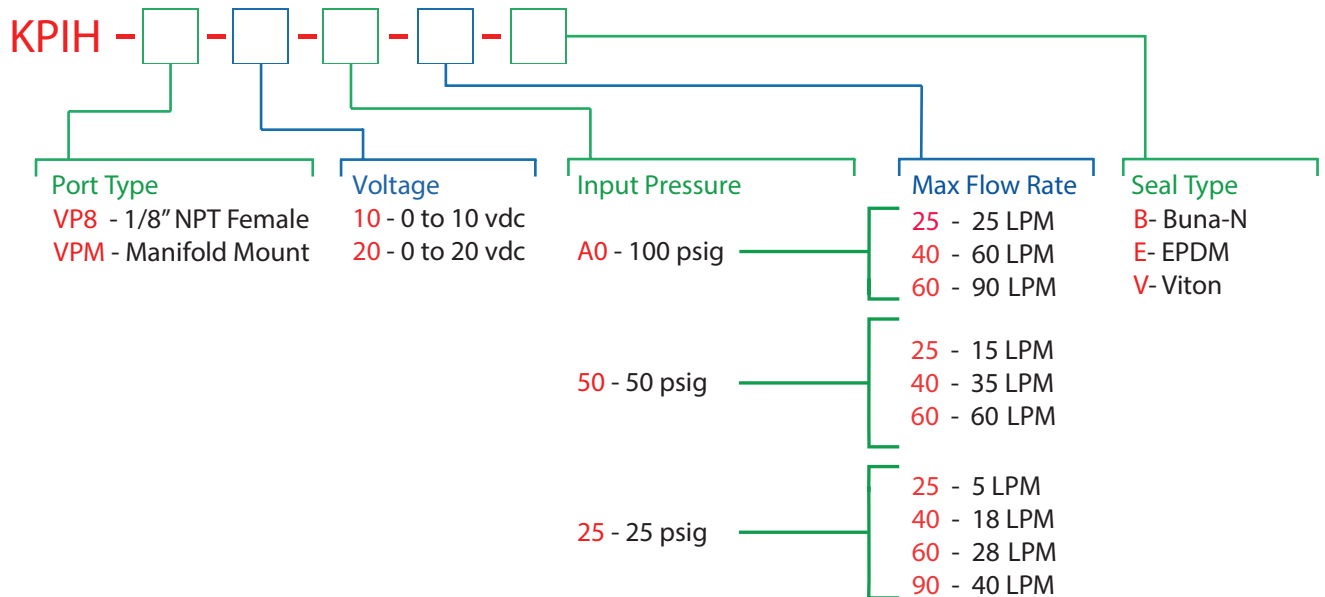

Performance Characteristics

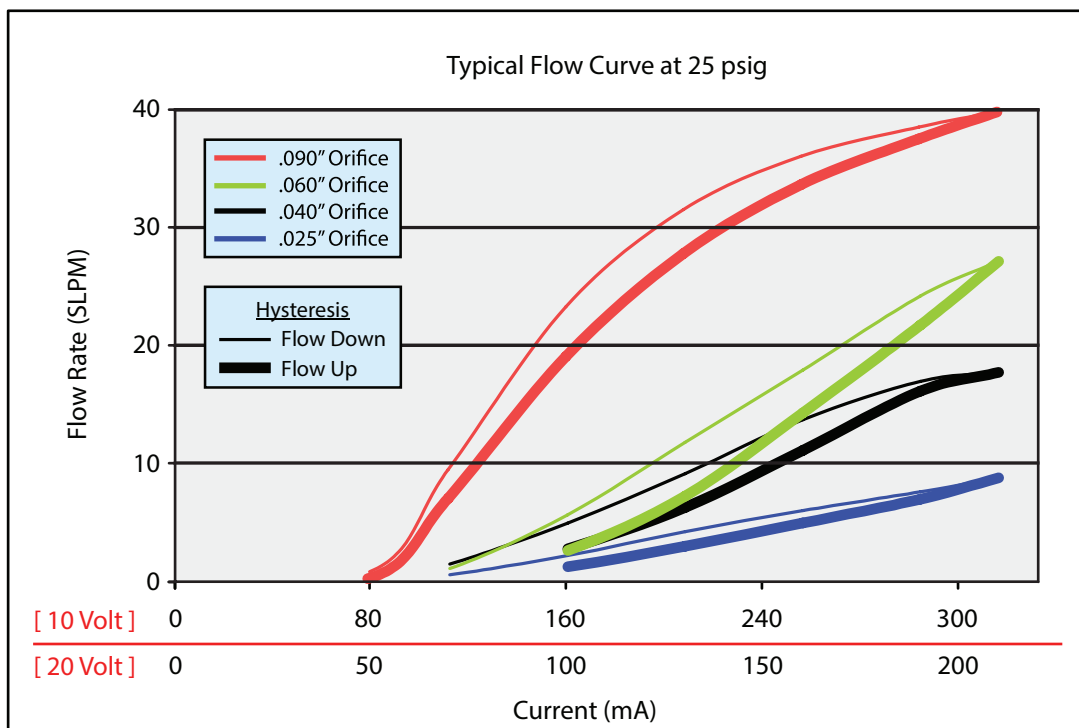

Performance Characteristics

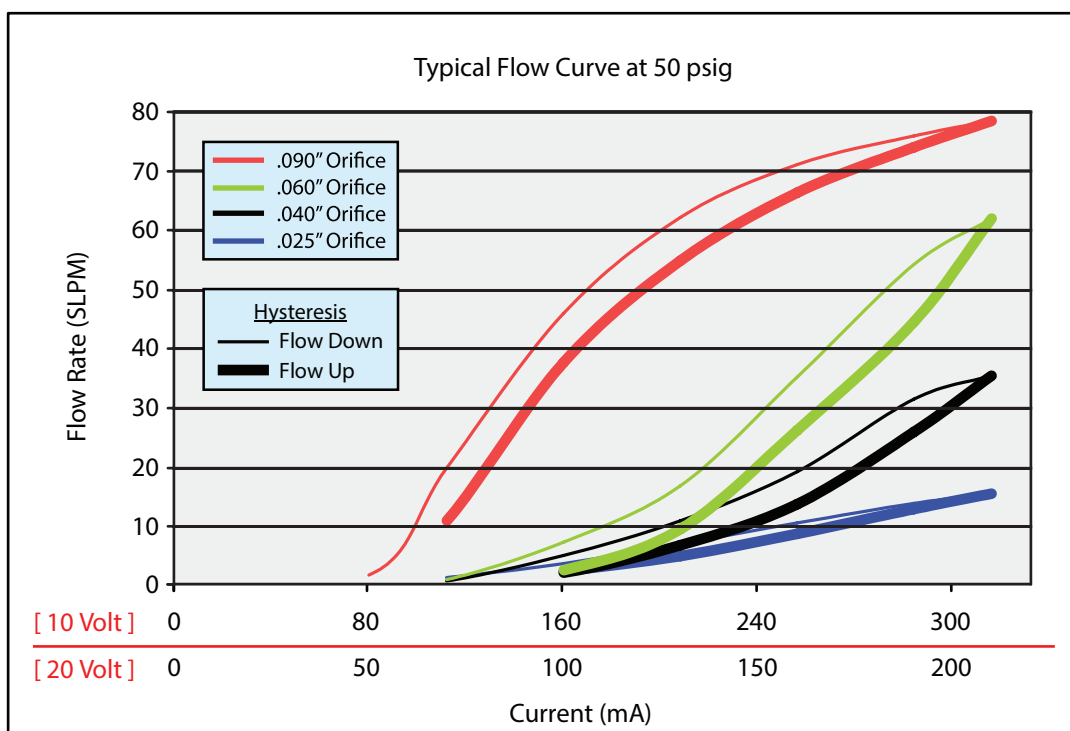

Performance Characteristics

