



# Digital Flow Meter



Kelly Pneumatics, Inc. offers a Digital Mass Flow Sensor for high volume flow rates of Air and Oxygen. The sensor automatically compensates for temperature changes in the measured gas and outputs accurate readings of mass flow and temperature via I2C digital communication.

The Digital Mass Flow Sensor outputs flow for Air and Oxygen from 0-300 SLPM, with an accuracy of 2% of reading, and offers a flow sample response time of 2 milliseconds. An internal microprocessor measures signals from an internal thermistor and hot wire anemometer to linearize flow measurements, and allows for numerous settings for flow and temperature output readings. The compact, lightweight design is perfect for OEM applications, especially medical, semiconductor and gas analyzer products.

## Product Features

- High Accuracy of  $\pm 2\%$  of reading (or 0.05 SLPM)
- 2 Millisecond Response time
- I2C Digital Communication to Read Flow or Temperature, and Change Pre Settings
- Temperature Compensating
- Microcontroller Design for Customization

## Microcontroller Features

The unit has an internal microprocessor which can be used to dynamically change settings. Digital Commands allow switching between flow measurements in either Air or Oxygen, as well as reading the current gas temperature. I2C commands can also change the units of flow measurement between Standard Liters per Minute (SLPM) or Pound Mass per Minute (lb/min). These preferences can also be saved to internal EEPROM to avoid initialization on start-up. Using a microcontroller also means custom software versions are available per your application's requirements.

# Specifications

Gas Calibration	
Media	Air and Oxygen
Flow Performance	
Range	0 to 300 SLPM
Accuracy	2% of reading or 0.05 SLPM, whichever is greater, at 70 °F and 14.7 psia
Response Time	2 milliseconds
Temperature Measurement	
Range	0 to 50 °C (0 to 122 °F)
Accuracy	±1 °C (±1.8 °F) at flows >1 SLPM
Power Requirement	
Voltage	5 volts ±10% (0.785 Watts Max Power Consumption at 300 SLPM)
Temperature Limits	
Operating	0 to 50 °C (0 to 122 °F)
Storage	-20 to 60 °C (-4 to 140 °F)
Communication Interface	
Interface	2-Wire I2C (see Application Note "I2C Details for KPI-DMFS-1" for more)

## Dimensions

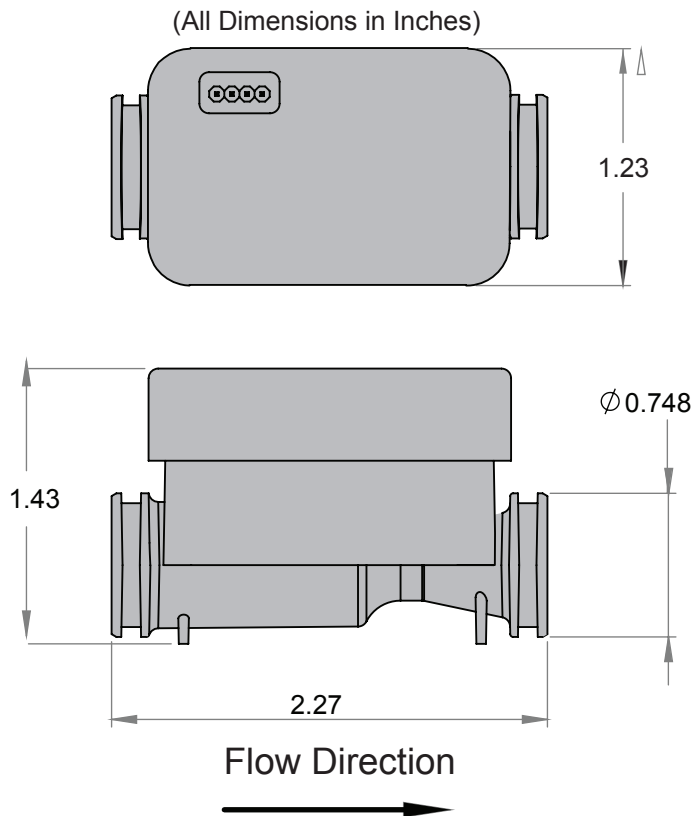

## Pin Layout

